

26EVOUVMANTI  
V090226MAN

English

EPA Est. No. 100154-GBR-1

EVOLUTION  
AQUA

INNOVATION IN WATER

evouVTi

Titanium Enhanced UV Clarifier

## INSTALLATION AND OPERATING MANUAL

### WARNING:

- Ensure that the unit is **switched off** at the mains before you attempt to conduct any type of maintenance on the UVC.
- Ensure the unit is installed in the recommended orientation.
- Fit the quartz sleeves and O-rings and switch on pump to check that unit is water tight before fitting the bulb, bulb socket and end cap.
- Ensure that the end cap is tight before running the unit.
- After replacing bulbs or before tightening the end cap, make sure that the O-Rings are in the correct position, and the bulb sockets are dry.
- If the electrical connections get wet, dry thoroughly before switching power on.
- **This unit should only be installed by a qualified electrician.**

## **EN** ENGLISH SAFETY WARNINGS

- This appliance is not intended for use by persons (including children) with reduced physical, sensory or mental capabilities, or lack of experience and knowledge, unless they have been given supervision or instruction concerning use of the appliance by a person responsible for their safety.
  - Children should be supervised to ensure that they do not play with the appliance.
  - If the supply cord is damaged, it must be replaced by a special cord or assembly available from the manufacturer or its service agent.
  - **WARNING:** Ultraviolet radiation. Avoid exposure to direct or reflected radiation.
  - Disconnect the appliance from the supply before replacing the UV source.
  - Do not operate the appliance if the protective enclosure or protective parts are removed or damaged.
  - Avoid exposure of eyes and skin to ultraviolet radiation.
- 

## **NL** DUTCH (NEDERLANDS) VEILIGHEIDSWAARSCHUWINGEN

- Dit apparaat is niet bedoeld voor gebruik door personen (inclusief kinderen) met verminderde fysieke, zintuiglijke of mentale capaciteiten of gebrek aan ervaring en kennis, tenzij onder toezicht of instructie.
  - Kinderen moeten onder toezicht staan om te voorkomen dat zij met het apparaat spelen.
  - Indien het netsnoer beschadigd is, moet dit worden vervangen door de fabrikant of diens serviceagent.
  - **WAARSCHUWING:** Ultraviolette straling. Vermijd blootstelling aan directe of gereflecteerde straling.
  - Koppel het apparaat los van de stroomvoorziening voordat u de UV-bron vervangt.
  - Gebruik het apparaat niet als beschermende onderdelen zijn verwijderd of beschadigd.
  - Vermijd blootstelling van ogen en huid aan ultraviolette straling.
- 

## **DE** GERMAN (DEUTSCH) SICHERHEITSWARNUNGEN

- Dieses Gerät ist nicht für Personen (einschließlich Kinder) mit eingeschränkten körperlichen, sensorischen oder geistigen Fähigkeiten oder mangelnder Erfahrung und Kenntnis bestimmt, es sei denn, sie werden beaufsichtigt oder eingewiesen.
  - Kinder sollten beaufsichtigt werden, damit sie nicht mit dem Gerät spielen.
  - Ist das Netzkabel beschädigt, muss es vom Hersteller oder seinem Kundendienst ersetzt werden.
  - **WARNUNG:** Ultraviolette Strahlung. Vermeiden Sie direkte oder reflektierte Strahlung.
  - Trennen Sie das Gerät vor dem Austausch der UV-Quelle vom Stromnetz.
  - Betreiben Sie das Gerät nicht, wenn Schutzteile entfernt oder beschädigt sind.
  - Vermeiden Sie die Exposition von Augen und Haut gegenüber UV-Strahlung.
- 

## **DK** DANISH (DANSK) SIKKERHEDSADVARSLER

- Apparatet er ikke beregnet til personer (inklusive børn) med nedsatte evner eller manglende erfaring uden opsyn eller instruktion.
  - Børn skal overvåges for at sikre, at de ikke leger med apparatet.
  - Hvis netledningen er beskadiget, skal den udskiftes af producenten eller servicepartner.
  - **ADVARSEL:** Ultraviolet stråling. Undgå direkte eller reflekteret eksponering.
  - Afbryd apparatet før udskiftning af UV-kilden.
  - Brug ikke apparatet, hvis beskyttelsesdele er fjernet eller beskadiget.
  - Undgå eksponering af øjne og hud for UV-stråling.
- 

## **FR** FRENCH (FRANÇAIS) AVERTISSEMENTS DE SÉCURITÉ

- Cet appareil n'est pas destiné à être utilisé par des personnes (y compris les enfants) ayant des capacités réduites ou un manque d'expérience, sauf sous surveillance ou instruction.
- Les enfants doivent être surveillés afin qu'ils ne jouent pas avec l'appareil.
- Si le cordon d'alimentation est endommagé, il doit être remplacé par le fabricant ou son service après-vente.
- **AVERTISSEMENT :** Rayonnement ultraviolet. Évitez toute exposition directe ou réfléchie.
- Débranchez l'appareil avant de remplacer la source UV.
- N'utilisez pas l'appareil si des pièces de protection sont retirées ou endommagées.
- Évitez toute exposition des yeux et de la peau aux rayonnements UV.

## **CZ** CZECH (ČEŠTINA)

### BEZPEČNOSTNÍ UPOZORNĚNÍ

- Spotřebič není určen pro osoby (včetně dětí) se sníženými schopnostmi nebo nedostatkem zkušeností bez dozoru nebo poučení.
- Děti musí být pod dohledem, aby si se spotřebičem nehrály.
- Pokud je napájecí kabel poškozen, musí být vyměněn výrobcem nebo servisem.
- VAROVÁNÍ: Ultrafialové záření. Vyhnete se přímému nebo odraženému záření.
- Před výměnou UV zdroje odpojte spotřebič od napájení.
- Nepoužívejte spotřebič, pokud jsou ochranné části odstraněny nebo poškozeny.
- Zabraňte vystavení očí a pokožky UV záření.

## **ES** SPANISH (ESPAÑOL)

### ADVERTENCIAS DE SEGURIDAD

- Este aparato no está destinado a personas (incluidos niños) con capacidades reducidas o falta de experiencia, salvo bajo supervisión o instrucción.
- Los niños deben ser supervisados para evitar que jueguen con el aparato.
- Si el cable de alimentación está dañado, debe ser sustituido por el fabricante o su servicio técnico.
- ADVERTENCIA: Radiación ultravioleta. Evite la exposición directa o reflejada.
- Desconecte el aparato antes de sustituir la fuente UV.
- No utilice el aparato si las protecciones están retiradas o dañadas.
- Evite la exposición de ojos y piel a la radiación UV.

## **PL** POLISH (POLSKI)

### OSTRZEŻENIA BEZPIECZEŃSTWA

- Urządzenie nie jest przeznaczone do użytku przez osoby (w tym dzieci) o ograniczonych zdolnościach lub braku doświadczenia, chyba że są nadzorowane lub poinstruowane.
- Dzieci powinny być nadzorowane, aby nie bawiły się urządzeniem.
- Uszkodzony przewód zasilający musi zostać wymieniony przez producenta lub serwis.
- OSTRZEŻENIE: Promieniowanie UV. Unikaj bezpośredniego lub odbitego promieniowania.
- Odłączyć urządzenie przed wymianą źródła UV.
- Nie używać urządzenia, jeśli osłony są usunięte lub uszkodzone.
- Unikaj narażenia oczu i skóry na promieniowanie UV.

## **EL** GREEK (ΕΛΛΗΝΙΚΑ)

### ΠΡΟΕΙΔΟΠΟΙΗΣΕΙΣ ΑΣΦΑΛΕΙΑΣ

- Η συσκευή αυτή δεν προορίζεται για χρήση από άτομα (συμπεριλαμβανομένων παιδιών) με μειωμένες σωματικές, αισθητηριακές ή πνευματικές ικανότητες, ή με έλλειψη εμπειρίας και γνώσεων, εκτός εάν επιβλέπονται ή έχουν λάβει οδηγίες σχετικά με τη χρήση της συσκευής από άτομο υπεύθυνο για την ασφάλειά τους.
- Τα παιδιά πρέπει να επιβλέπονται ώστε να διασφαλίζεται ότι δεν παίζουν με τη συσκευή.
- Εάν το καλώδιο τροφοδοσίας είναι κατεστραμμένο, πρέπει να αντικατασταθεί με ειδικό καλώδιο ή συγκρότημα που διατίθεται από τον κατασκευαστή ή από εξουσιοδοτημένο κέντρο σέρβις.
- ΠΡΟΕΙΔΟΠΟΙΗΣΗ: Υπεριώδης ακτινοβολία. Αποφύγετε την έκθεση σε άμεση ή ανακλώμενη ακτινοβολία.
- Αποσυνδέστε τη συσκευή από την παροχή ρεύματος πριν αντικαταστήσετε την πηγή UV.
- Μην λειτουργείτε τη συσκευή εάν το προστατευτικό περίβλημα ή τα προστατευτικά μέρη έχουν αφαιρεθεί ή έχουν υποστεί ζημιά.
- Αποφύγετε την έκθεση των ματιών και του δέρματος σε υπεριώδη ακτινοβολία.

## **SA** ARABIC — العربية

### تحذيرات السلامة

- هذا الجهاز غير مخصص للاستخدام من قبل الأشخاص (بما في ذلك الأطفال) الذين لديهم قدرات بصرية أو حسية أو عقلية محدودة، أو نقص في الخبرة والمعرفة، ما لم يتم إشرافهم أو تعليمهم على استخدام الجهاز من قبل شخص مسؤول عن سلامتهم.
- يجب مراقبة الأطفال لضمان عدم لعبهم بالجهاز.
- إذا تلف سلك الإمداد، يجب استبداله بسلك خاص أو مجموعة متوفرة من الشركة المصنعة أو وكيل الخدمة الخاص بها.
- تحذير: إشعاع فوق بنفسجي. تجنب التعرض للإشعاع المباشر أو المنعكس.
- أفضل الجهاز عن مصدر الطاقة قبل استبدال مصدر الأشعة فوق البنفسجية.
- لا تشغيل الجهاز إذا تم إزالة الغلاف الواقي أو الأجزاء الواقية أو إذا كانت تالفة.
- تجنب تعرض العينين والجلد للإشعاع فوق البنفسجي.

# IMPORTANT SAFETY INFORMATION

## READ AND FOLLOW ALL INSTRUCTIONS



Read these instructions carefully before installing or using the appliance. Keep this instruction manual for future reference. Failure to follow these instructions may result in electric shock, exposure to hazardous UV radiation, or damage to the appliance.

### GENERAL SAFETY WARNINGS

- This appliance is not intended for use by persons (including children) with reduced physical, sensory or mental capabilities, or lack of experience and knowledge, unless they have been given supervision or instruction concerning use of the appliance by a person responsible for their safety.
- Children shall not play with the appliance.
- Cleaning and user maintenance shall not be made by children without supervision.
- If the supply cord is damaged, it must be replaced by the manufacturer, its service agent or similarly qualified persons in order to avoid a hazard.
- Always disconnect the appliance from the power supply before carrying out maintenance, cleaning or lamp replacement.
- Do not operate the appliance if the protective enclosure or protective parts are removed or damaged.

### UV-C RADIATION SAFETY WARNINGS

**WARNING** - UV radiation is dangerous to the eyes and skin.  
Do not operate the UV-C emitter outside the appliance.



- This appliance contains a UV-C emitter.
- Operation of the appliance with the UV-C emitter removed from the appliance enclosure is prohibited.
- Operation of the appliance with damaged housing may result in exposure to hazardous UV-C radiation.
- The UV-C emitter must be switched off and disconnected from the power supply before opening the appliance.



### INTENDED USE

- This appliance is intended exclusively for the treatment of water using ultraviolet (UV-C) radiation.
- The appliance is intended for use in aquariums, ponds, garden ponds and similar water systems.
- This appliance is not intended for use with drinking water.
- The appliance is intended for use with water only.



### FORESEEABLE MISUSE

The following uses are considered misuse and are prohibited:

- Operation of the appliance without water flow
- Operation of the appliance with damaged housing, quartz sleeve or seals
- Operation of the UV-C emitter outside the appliance
- Use of the appliance for purposes other than water treatment
- Modification of the appliance or use of non-approved components

Unintended use of the appliance or damage to the housing may result in the escape of hazardous UV-C radiation.

# SAVE THESE INSTRUCTIONS

EPA Est. No. 100154-GBR-1

# IMPORTANT SAFETY INFORMATION



## ELECTRICAL SAFETY

- The appliance must be supplied through a residual current device (RCD) having a rated residual operating current not exceeding 30 mA.
- The appliance must only be connected to a power supply of the voltage and frequency specified on the rating label.
- Do not use extension leads or adapters.
- Do not operate the appliance if the power cable or plug is damaged.

**WARNING** - (USA models): Risk of electric shock. Connect only to a branch circuit protected by a GFCI. If you cannot verify GFCI protection, contact a qualified electrician.

## WATER AND INSTALLATION SAFETY

- The appliance shall only be installed in accordance with these instructions.
- The appliance shall not be installed where it may be subject to freezing conditions.
- The appliance shall only be operated within the specified minimum and maximum water temperatures of 0° to 40°.
- The appliance shall only be operated within the specified maximum operating pressure.
- Max operating pressure - 2.5 Bar (37 PSI)

## INSTALLATION INSTRUCTIONS

- Install the appliance only in accordance with these instructions.
- Ensure that the appliance is correctly supported and that no mechanical stress is applied to the housing or pipe connections.
- Ensure that all electrical connections are protected from water ingress.

## COMMISSIONING AND OPERATION

- Fill the system with water before connecting the appliance to the power supply.
- Check the appliance for leaks before switching on.
- Do not operate the appliance without water flow.
- During normal operation, the appliance may become warm.

## UV-C EMITTER REPLACEMENT

**WARNING** - Disconnect the appliance from the power supply before replacing the UV-C emitter.

- Only replacement UV-C emitters specified by the manufacturer may be used.
- The UV-C emitter shall never be operated outside the appliance.
- After replacing the UV-C emitter, ensure that all seals are correctly installed before reconnecting the appliance to the power supply.

# SAVE THESE INSTRUCTIONS

EPA Est. No. 100154-GBR-1

# IMPORTANT SAFETY INFORMATION



## MAINTENANCE AND CLEANING

**WARNING** - Disconnect the appliance from the power supply before carrying out maintenance or cleaning.

- Clean the quartz sleeve at regular intervals to maintain UV performance.
- Only use clean water and a soft cloth for cleaning.
- Do not use abrasive cleaners or solvents.

## FAULT CONDITIONS

- If the appliance shows signs of malfunction, unusual noise, leakage or damage, disconnect it immediately from the power supply.
- Do not operate the appliance if it is visibly damaged.
- Repairs shall only be carried out by qualified personnel or the manufacturer.

## DISPOSAL

- This appliance shall not be disposed of with household waste.
- Electrical and electronic equipment must be disposed of in accordance with local regulations.
- UV-C emitters shall be disposed of in accordance with applicable waste regulations.

Your product is designed and manufactured with high quality material and components, which can be recycled and reused. When this crossed out wheeled bin symbol is attached to a product, it means the product is covered by the European Directive 2002/96/EC. Please contact your local authority about correct disposal for electrical and electronic equipment. Our WEE Registration Number is WEE/FE1471RR.



Please act according to your local rules and do not dispose of your old products with your normal household waste. The correct disposal of your old product will help prevent potential negative consequences for the environment and human health.

## COMPLIANCE INFORMATION

This appliance has been designed and manufactured in accordance with the following standards and directives:

IEC / EN 60335-1

IEC / EN 60335-2-109

Low Voltage Directive 2014/35/EU

Electromagnetic Compatibility Directive 2014/30/EU

UK Electrical Equipment (Safety) Regulations

## SERVICE INFORMATION

For service, spare parts or technical support, contact the manufacturer or authorised service agent. Repairs carried out by unauthorised persons may result in loss of warranty and non-compliance.

# SAVE THESE INSTRUCTIONS

EPA Est. No. 100154-GBR-1

## **EUVOUV TI TITANIUM ENHANCED UV CLARIFIER**

Evolution Aqua evoUV Ti, Titanium Enhanced UV Clarifiers are made using the latest technology and are lined with a thick and polished titanium tube, to clear green pond water fast.

When the UV light strikes the internal surface of the titanium chamber it produces an instant photocatalytic reaction and generates Hydroxyl Radicals, a powerful oxidant, that instantly destroys organic and inorganic matters, neutralising water-born algae, bacteria and viruses resulting in clearer water whilst being perfectly safe for all pond life.

### **UNBOXING THE UV**

On unpacking, you will see that the UV bulb and quartz sleeve are packed separately for safe transit. Please refer to pages 11 and 19 of this manual for instructions on how to install the bulb and quartz sleeve. Quartz Sleeve O-Rings and End Cap O-Rings are packed in separate small bags inside the box.

Stainless steel mounting brackets and screws are also supplied in bags and need to be fitted. On the 110 UV, the mounting brackets can be found in the cardboard end fitments.

110 UV includes a 2" to 63mm connector that is for EUROPEAN customers only - NOT UK.

### **CONTENTS**

UV Diagram And Components List	PAGES 8 - 9
Flow Rates	PAGE 10
Installing The Quartz Sleeve	PAGE 11
Positioning And Mounting The UV	PAGE 12
Connection To Your Pipework	PAGE 14
Water Testing	PAGE 17
Connection To The Electricity Supply	PAGE 18
Installing The UV Bulb	PAGE 19
UV Bulb Replacement	PAGE 20
Replacing / Cleaning The Quartz Sleeve	PAGE 21
Electrical Box Replacement	PAGE 22
In Built Protection	PAGE 22
Troubleshooting	PAGE 23
Frequently Asked Questions	PAGE 24
Guarantee	PAGE 25

# 55W UV DIAGRAM AND COMPONENTS LIST

Please familiarise yourself with the components shown in the diagram below:

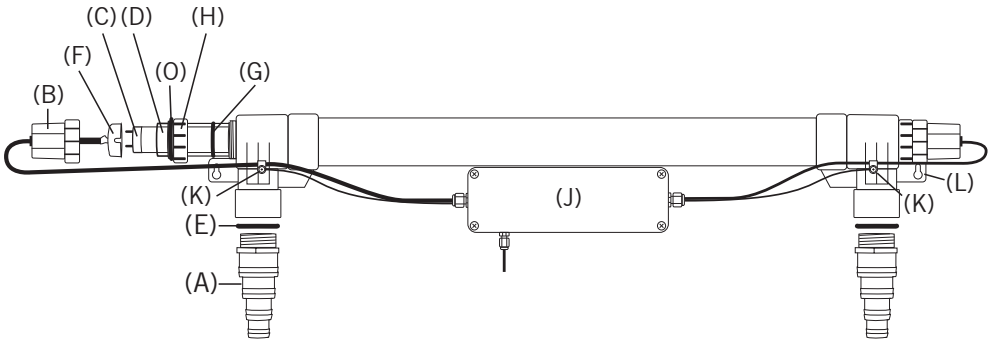

Description	Label	Qty	Order Code
Inlet / Outlet - 1½ Hosetail	<b>A</b>	<b>2</b>	HOSETAIL15TH
End Cap	<b>B</b>	<b>2</b>	EVOCONNUT
UV Bulb	<b>C</b>	<b>1</b>	Available from your EA dealer
Quartz Sleeve	<b>D</b>	<b>1</b>	Available from your EA dealer
Hosetail O-Ring	<b>E</b>	<b>2</b>	EVOUVORINGHOSET
Bulb Socket	<b>F</b>	<b>2</b>	LAMPHOLDER-T8
Quartz Sleeve O-Ring	<b>G</b>	<b>2</b>	EVOUVORING2
Locking Nut	<b>H</b>	<b>2</b>	EVO-M/F
Electrical Box	<b>J</b>	<b>1</b>	Available from your EA dealer
Cable Clip	<b>K</b>	<b>2</b>	-
Mounting Bracket	<b>L</b>	<b>2</b>	-
End Cap O-Ring	<b>O</b>	<b>2</b>	UVECORING

## IDENTIFYING THE O-RINGS

These are packed in small bags inside the packaging.

Spare Part Order code: **EVOUVSPARESML**

You will receive two Quartz Sleeve O-Rings and two End Cap O-Rings with this spare part.



2 x Quartz Sleeve O-Ring (**G**)



2 x End Cap O-Ring (**O**)

# 110W UV DIAGRAMS AND COMPONENTS LIST

Please familiarise yourself with the components shown in the diagram below:

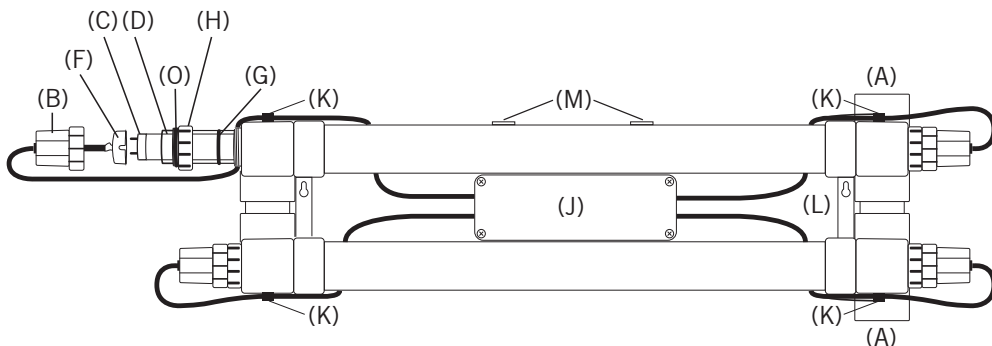

Description	Label	Qty	Order Code
Inlet / Outlet	<b>A</b>	-	-
End Cap	<b>B</b>	<b>4</b>	EVOCONNUT
UV Bulb	<b>C</b>	<b>2</b>	Available from your EA dealer
Quartz Sleeve	<b>D</b>	<b>2</b>	Available from your EA dealer
Bulb Socket	<b>F</b>	<b>4</b>	LAMPHOLDER-T8
Quartz Sleeve O-Ring	<b>G</b>	<b>4</b>	EVOUVORING2
Locking Nut	<b>H</b>	<b>4</b>	EVO-M/F
Electrical Box	<b>J</b>	<b>1</b>	Available from your EA dealer
Cable Clip	<b>K</b>	<b>2</b>	-
Mounting Bracket	<b>L</b>	<b>2</b>	-
End Cap O-Ring	<b>O</b>	<b>4</b>	UVECORING

Two 2" imperial to 63mm metric reducers are supplied. These are only for use by EUROPEAN customers to connect to metric pipe. 2" connectors are available to buy from EA stockists.

## IDENTIFYING THE O-RINGS

These are packed in small bags inside the packaging.

Spare Part Order code: **EVOUVSPARELGE**

You will receive four Quartz Sleeve O-Rings and four End Cap O-Rings with this spare part.



4 x Quartz Sleeve O-Ring (**G**)



4 x End Cap O-Ring (**O**)

## FLOW RATES

**Please note:** For optimum performance we recommend that you pass the entire volume of your pond through the evoUV Ti unit once every 2 to 3 hours. We do not recommend the use of pumps with operating pressures in excess of 2.5 bar (37 psi).

Model	Max. pond size	Optimum flow rate	Max. flow rate	Bulb power	Inlet / Outlet	Fittings supplied
evo55Ti	55,000 Litres 12,100 UK Gallons 14,500 US Gallons	15,000 Litres/hr 3,300 UK Gallons/hr 4,000 US Gallons/hr	20,000 Litres/hr 4,400 UK Gallons/hr 5,000 US Gallons/hr	55W (1 X 55W T8 LAMP)	1½"	2 x 1½" Threaded Hosetails
evo110Ti	75,000 Litres 16,500 UK Gallons 19,500 US Gallons	20,000 Litres/hr 4,400 UK Gallons/hr 5,000 US Gallons/hr	25,000 Litres/hr 5,500 UK Gallons/hr 6,000 US Gallons/hr	110W (2 X 55W T8 LAMP)	2"	No Fittings Supplied

Your evoUV Ti will keep your pond clear of green water up to its maximum capacity. However, it is important to note that there are factors that affect how you select the right size of evoUV Ti for your pond.

You will need to take into consideration such things as stocking levels, sunlight / shade, daily sunshine amounts etc. This is not always possible to calculate, and if this is the case, use the table below as a guide. It must be stressed however, that these are only guidelines, and you should take advice from your local Evolution Aqua dealer.

USA - Southern States / Mediterranean	3 Watts UV per 1,000 litres
Northern Europe including UK	2 Watts UV per 1,000 litres
USA - Northern States / Canada	1 Watts UV per 1,000 litres

## INSTALLING THE QUARTZ SLEEVE

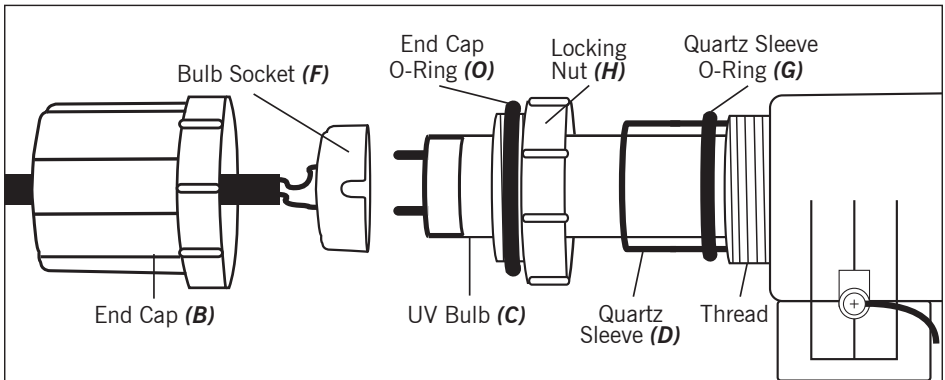

1. Starting at one end of the unit, unscrew the black end cap (**B**). You will notice that this black end cap houses the bulb socket (**F**).
2. Unscrew the white locking nut (**H**) from the same end.
3. Repeat steps 1 and 2 at the other end of the unit.
4. Take the quartz sleeve (**D**) from the packaging box and slide it through the UV until it finds the hole at the far end of the unit.
5. Take the quartz sleeve O-Ring (**G**) and fit it around one end of the quartz sleeve.
6. Slide this quartz sleeve O-Ring (**G**) towards the thread on the UV body, ensuring that equal amounts of quartz sleeve are visible at each end of the unit.
7. Fit the quartz sleeve O-Ring (**G**) at the other end of the quartz sleeve, again ensuring that equal amounts of quartz sleeve are visible at each end of the unit.
8. Now screw the white locking nut (**H**) back into position.
9. Ensure the locking nut is **HAND TIGHTENED** to prevent causing damage to the O-Ring. No tools are needed.
10. Repeat steps 8 and 9 at the other end of the unit.
11. The quartz sleeve is now in position ready to take the UV bulb.
12. Run for 24 hours to check the installation is correct with no leaks. See page 17 for details. Re-install if any leaks are detected - if no leaks proceed to lamp installation.

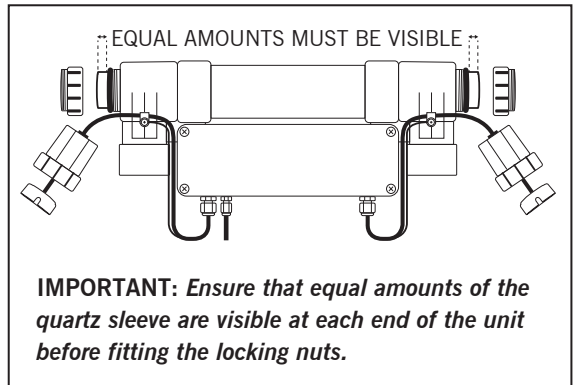

**HAND TIGHTEN FITTINGS ONLY - DO NOT USE TOOLS**

## POSITIONING AND MOUNTING THE UV

### Fitting mounting brackets (55W)

Stainless steel brackets and screws can be found in bags inside the packaging. You will need to install these mounting brackets to the **rear of the UV** at each end using a 3mm allen key. **HAND TIGHTEN ONLY.**

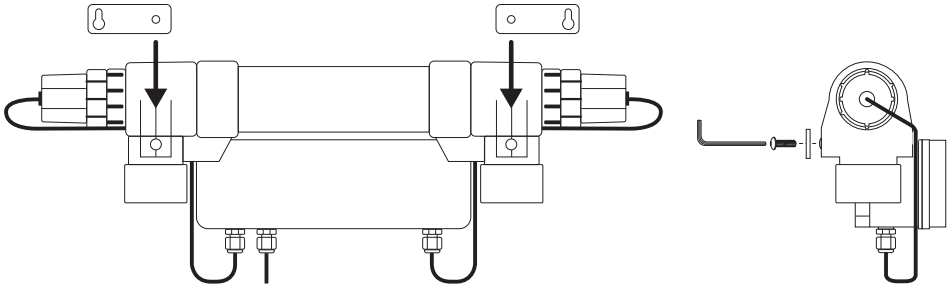
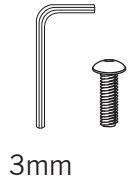

### Fitting mounting brackets (110W)

Stainless steel mounting brackets, nuts and bolts can be found inside the packaging. On the 110 UV, you can find the two mounting brackets inside the cardboard fitting inside the box. Nuts and bolts are packed in a small bag. You will need to install these mounting brackets to the **rear of the UV** at each end. Use an 8mm nut runner and spanner. **HAND TIGHTEN ONLY.**

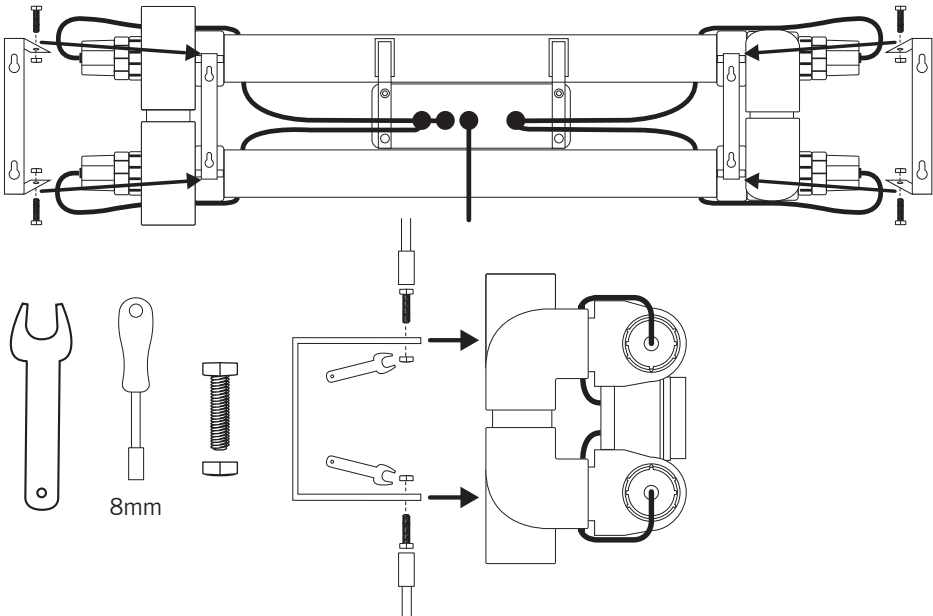

## POSITIONING AND MOUNTING THE UV

If you are going to position your evoUV Ti outside or in an area where it is likely to get splashed regularly with water, then you must mount the unit the correct way up.

Your evoUV Ti must not be submerged in water or placed in a position where water may collect around the unit. The electrics within the evoUV Ti units are sealed in a showerproof unit. evoUV Ti has an IP rating of IP65.

Please ensure that there is enough space at one end of the evoUV Ti to enable bulb / quartz sleeve removal and maintenance.

**PLEASE NOTE:** Wall mounting screws and wall plugs are not provided.

If installing the unit prior to or without a pond filter, we would recommend the use of a pre-filter on the water pump to prevent excess solids from being pumped into the unit. The evoUV Ti may be connected to the water flow on any pumped line, this could be, for instance, a skimmer line or any other additional pumped line. The two most common forms of set up are pump fed and gravity fed, shown below:

### Pump Fed Installation

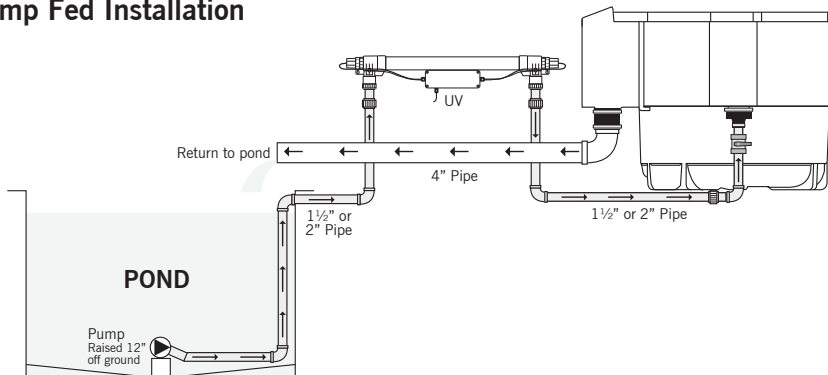

### Gravity Fed Installation

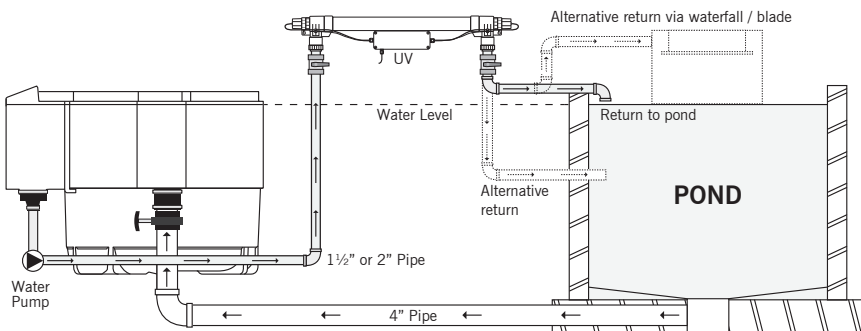

We recommended installing a ball valve either side of the evoUV Ti for maintenance.

## CONNECTION TO YOUR PIPEWORK - FLEXIBLE HOSE

### IMPORTANT: DO NOT OVERTIGHTEN FITTINGS.

The two universal hosetails supplied with the evoUV Ti, should be screwed into the inlet / outlet at either end of the unit. Hosetails should be tightened using hand pressure only. Ensure that the O-Rings are in position before assembling. Please note that there is no correct direction of flow through the unit, either end may be used as the inlet or outlet.

### CONNECTION WITH FLEXIBLE HOSE (EVO55TI ONLY)

The evoUV Ti is supplied with two universal hosetails to take  $\frac{3}{4}$ ", 1",  $1\frac{1}{4}$ ", and  $1\frac{1}{2}$ " diameter flexible hose. If you are using one of the two larger sizes, the smaller sections of the hosetails must be cut off to ensure sufficient water flow and to prevent possible damage to the pump. We recommend that you use the largest diameter hose available. The hosetails should be trimmed away from the unit as shown in the diagram below. Once the hosetails have been trimmed, attach them to the unit as shown below. Secure the flexi-hose to the hosetail with a stainless steel hose clip (not provided).

Cut the hosetail to the size required and discard the off-cut. **DO NOT OVERTIGHTEN.**

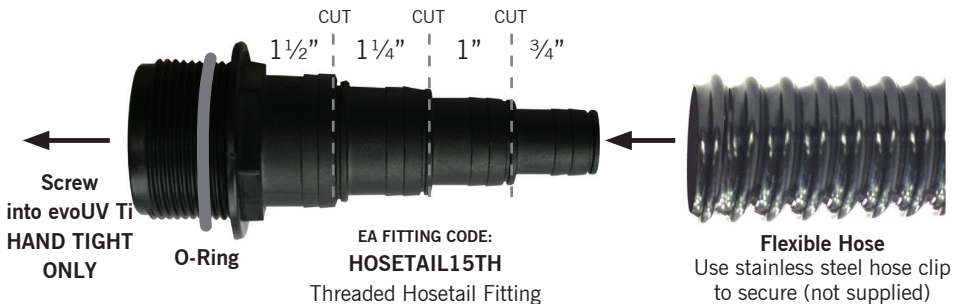

### CONNECTING EVO110 UV TO FLEXIBLE HOSE

The evo110 is not supplied with any fittings to connect to imperial sized pipework. To install the evo110 to flexible hose, you can purchase a **EVO UV 110W UV FLEXI PIPE KIT** from Evolution Aqua or any EA stockist (**EA Code:** EVOUV110FLEX).

This kit includes solvent weld hosetails, reducing sleeves and reducing bushes. Once you glue these parts together and fit them to the evo110 you can then connect  $1\frac{1}{2}$ " diameter flexible hose.

**PLEASE NOTE:** Any adaptors supplied with the evo110 are for European customers only to help them convert from 2" to 63mm pipe. These are not for use in the UK.

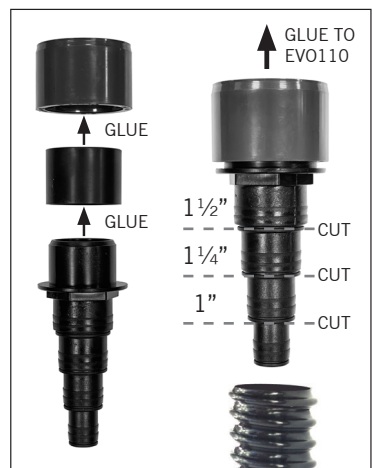

## CONNECTION TO YOUR PIPEWORK - PRESSURE PIPE

CONNECTION TO IMPERIAL PRESSURE PIPE - DO NOT OVERTIGHTEN FITTINGS.

The unit may also be rigid plumbed by the use of adaptors and solvent weld adhesive, available from Evolution Aqua stockists.

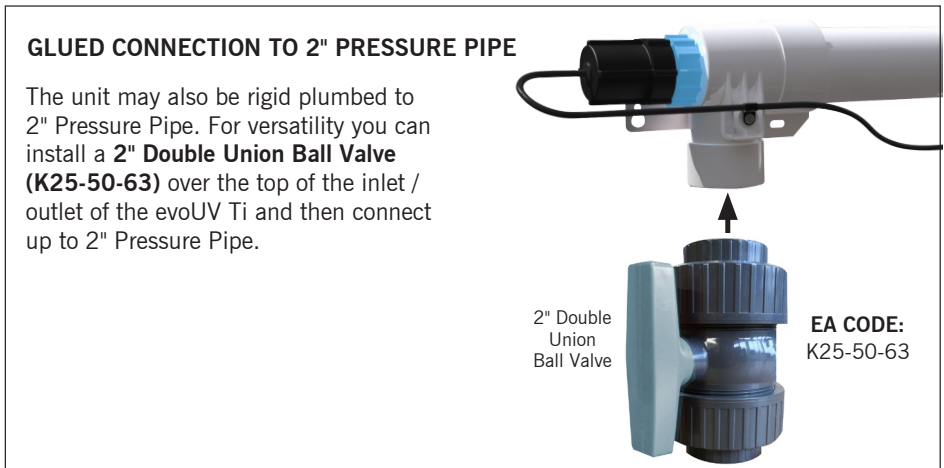
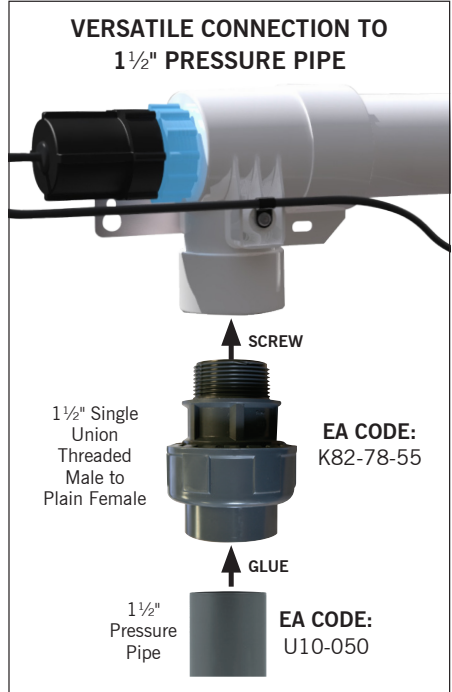
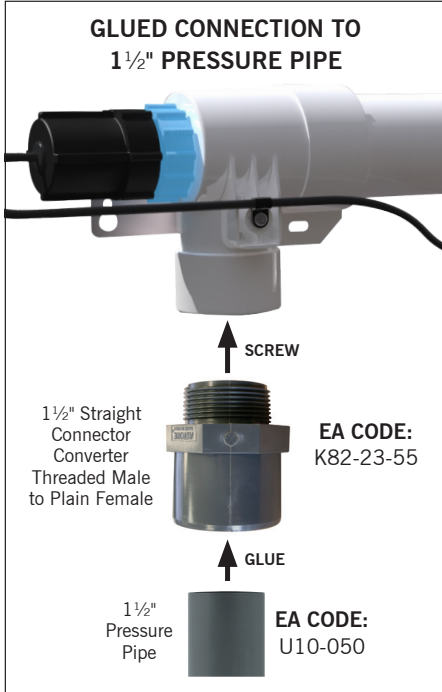

## CONNECTION TO YOUR PIPEWORK - EVO110 - PRESSURE PIPE

### CONNECTION TO IMPERIAL PRESSURE PIPE - DO NOT OVERTIGHTEN FITTINGS.

The evo110 may also be rigid plumbed to 2" Pressure Pipe by the use of adaptors and solvent weld adhesive, available from Evolution Aqua stockists.

**PLEASE NOTE:** Any adaptors supplied with the evo110 are for European customers only to help them convert from 2" to 63mm pipe. These are not for use in the UK.

#### GLUED CONNECTION TO 2" PRESSURE PIPE

The unit may also be rigid plumbed to 2" Pressure Pipe.

We advise you to fit a length of 2" pipe into the inlet and outlet and then glue:

**2" Double Union Ball Valve (K25-50-63)**

or

**2" Plain Female to Plain Female Single Union (K82-74-66).**

#### CONNECTION TO FLEXIBLE HOSE

To connect the evo110 to flexible hose please purchase a **EVO UV 110W UV FLEXI PIPE KIT** from Evolution Aqua or any EA stockist.

**EA CODE: EVOUV110FLEX**

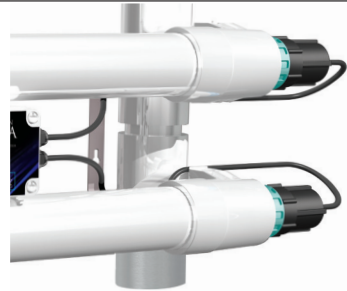

↑ GLUE



2" Pressure Pipe



2" Single Union  
Plain Female to  
Plain Female

**EA CODE:**  
K82-74-66



2" Double  
Union  
Ball Valve

**EA CODE:**  
K25-50-63

## CONNECTION TO METRIC PIPEWORK - EUROPE ONLY (NOT UK)

In countries where metric pipework is used, you can connect all evoUV Ti to 63mm pipe.

On **evo55Ti models**, we recommend using a **2" to 63mm Plain Female Straight Connector Converter (K81-25-66)** (*not supplied*). This can be glued directly onto the inlet / outlet of the evo55Ti models and then to 63mm pipe.

For EUROPEAN versions of the **evo110**, **adapters are supplied** in the box to allow connection to 63mm pipe. (NOT UK MODELS)

## WATER TESTING THE QUARTZ, O-RINGS AND LOCKING NUTS

Now that the unit is in position and connected to pipework, the quartz sleeve and O-ring at each end can be leak tested to ensure that they have been fitted properly. Failure to test for leaks and improper installation at this stage may cause water to seep into and damage the bulb socket.

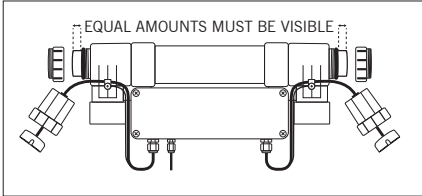

**STEP 1:** Fit quartz sleeve, o-rings and locking nuts.

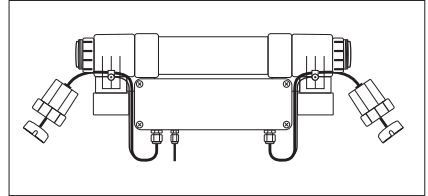

**STEP 2:** Check the locking nuts are hand tight only.

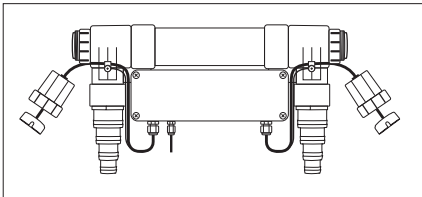

**STEP 3:** Position and mount UV and connect inlet and outlet connections.

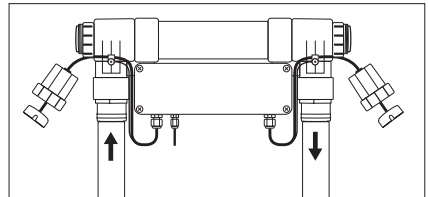

**STEP 4:** Connect up to pipework and turn on pump to start water flow.

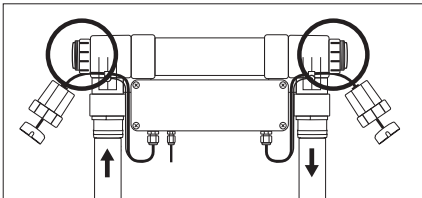

**STEP 5:** Check locking nuts for signs of water leaking.

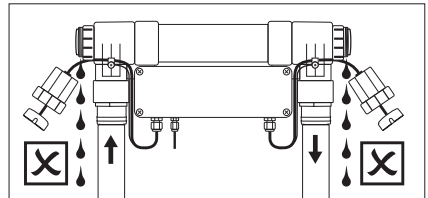

**STEP 6:** If water seeps from locking nuts, check quartz sleeve installation. See Troubleshooting on page 21.

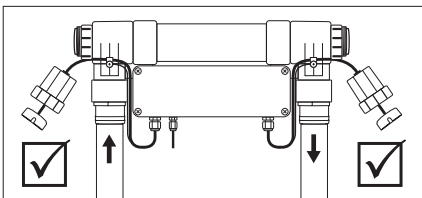

**STEP 7:** If no water leaks, quartz sleeve has been properly installed. Proceed to connecting the UV to the power supply.



## WARNING

Failure to test for leaks and improper installation at this stage may cause water to seep into and damage the bulb socket and ballast. Water damage from improper installation is **NOT** covered under warranty.

## CONNECTION TO THE ELECTRICITY SUPPLY

**Electrical installations must be done by a qualified electrician.**

The power supply must meet the specifications on the product. The cores in the supply cable are coloured in accordance with the following code:



### UK / EU:

Brown = Live  
Blue = Neutral  
Green / Yellow = Earth

### USA WIRING

Black = Live  
White = Neutral  
Green = Earth



Do not use the supply cable to lift the UV as this may cause damage.

**WARNING** - A Residual Current Device (RCD), also known as the Residual Current Circuit Breaker (RCCB), with a tripping current not exceeding 30mA must be installed in the supply circuit. A means of disconnection from the supply having a contact separation of at least 3mm in all poles must be incorporated in the wiring.

**Caution:** Use in the area of a pond only if the installation complies with the relevant wiring regulations. Please consult a qualified electrician.

All electrical installations and wiring must be adequately protected to prevent any damage.

Enough electrical cable is supplied with the unit to connect to the mains electric. This unit must be connected to permanent wiring. A switch with 3mm contact separation must be provided in the fixed wiring to provide disconnection from the electricity supply.

It is recommended that the UV unit is wired in conjunction with the pump so that when the pump is turned off, so is the UV unit.

## USA SPECIFIC

EPA Est. No. 100154-GBR-1

**GROUNDING INSTRUCTIONS** - This appliance must be grounded. In the event of a malfunction or breakdown, grounding will reduce the risk of electric shock by providing a path of least resistance for electric current. This appliance is equipped with a cord having an appliance-grounding conductor and a grounding plug. The plug must be plugged into an appropriate outlet that is installed and grounded in accordance with all local codes and ordinances.

**WARNING** - Improper connection of the appliance-grounding conductor can result in a risk of electric shock. Check with a qualified electrician or service representative if you are in doubt whether the appliance is properly grounded. Do not modify the plug provided with the appliance; if it will not fit the outlet, have a proper outlet installed by a qualified technician.

## INSTALLING THE UV BULB



1. Remove all packaging from the UV bulb (C).
2. Slide the UV bulb (C) carefully through the quartz sleeve (D) that you have just fitted and tested, as per the instructions on pages 11 and 17.
3. While holding one of the black end caps (B) gently push the cable through the end cap which will make it easier to fit the bulb socket (F) in step 5.  
**IMPORTANT: Do not pull the cable by holding just the bulb socket.**
4. Fit the End Cap O-Ring (O) over the thread on the white locking nut.  
**IMPORTANT: Ensure the End Cap O-Ring is butted up against the locking nut collar.**
5. In no particular order, align the UV bulb pins with the holes in the bulb socket and carefully push the bulb socket firmly onto the UV bulb pins. You may need to hold the other end of the UV bulb to help you fit the socket.
6. Ensure the UV bulb socket is firmly connected to the UV bulb.
7. Repeat steps 3 to 6 at the other end of the unit.
8. Now at one end of the unit, slide the black end cap over the bulb socket while carefully holding the cable to prevent the bulb connector disconnecting from the UV bulb.
9. Screw this end cap onto the thread on the white locking nut (H) already connected to the UV body. **HAND TIGHTEN ONLY.** This will then compress the End Cap O-Ring to form a watertight seal.
10. Repeat steps 8 and 9 at the other end of the unit.
11. Check that all of the fittings are hand tightened. No tools are needed.
12. On multiple bulb units, do not mix up the bulb connectors as this will result in the bulb not illuminating.

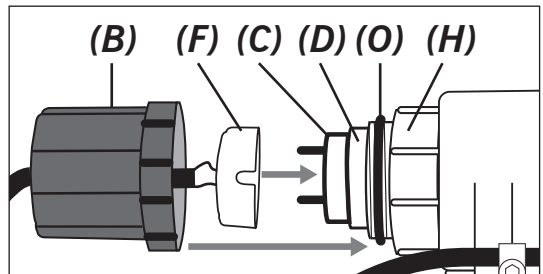

Please ensure that there is enough space at one end of the UV to enable bulb / quartz sleeve removal and maintenance.

**HAND TIGHTEN FITTINGS ONLY - DO NOT USE TOOLS**

## UV BULB REPLACEMENT

**ALWAYS ISOLATE THE UNIT FROM ANY ELECTRICITY AND WATER SUPPLY BEFORE CARRYING OUT MAINTENANCE ON THE UNIT.**

### **TO REMOVE A UV BULB:**

It is not necessary to stop the water circulating through the UV to change the bulb.

1. Disconnect the electricity supply.
2. Unscrew the black end cap at one end of the unit. Take care not to unscrew the white locking nut and ensure the End Cap O-Ring remains in place.
3. Carefully slide the black end cap over the wire to reveal the bulb socket.
4. Disconnect the bulb socket.
5. Repeat steps 2 to 4 at the other end of the UV.
6. With the end caps out of the way, carefully slide out the UV bulb.

**WARNING:** If the end caps / electrical connections get wet during this procedure, please ensure that they are thoroughly dried before re-connecting.

### **TO INSTALL A NEW UV BULB:**

Follow the instructions on **page 19** to fit a new UV bulb.

**IMPORTANT:** After checking all the fittings are correctly tightened you can switch your unit back on.

As already mentioned, it is essential that the unit is protected from frost during the winter months, or disconnected from water and electricity supplies and stored indoors. During the spring and summer season, the quartz sleeve, which separates the UV bulb from the water passing through the unit, will need to be cleaned two or three times. This is essential, as dirt or limescale building up on the quartz sleeve will inhibit the penetration of the ultraviolet light into the water and affect the efficient working of the unit.

## REPLACING / CLEANING QUARTZ SLEEVE

**DANGER: ULTRAVIOLET RADIATION. Disconnect Power Before Replacing Lamp**  
**ALWAYS ISOLATE THE UNIT FROM ANY ELECTRICITY AND WATER SUPPLY BEFORE CARRYING OUT MAINTENANCE ON THE UNIT.**

### TO REMOVE A QUARTZ SLEEVE:

**PLEASE NOTE:** Removing the quartz sleeve will cause water to flow out of the unit. Flow can be directed to the bypass using the installed bypass. If no bypass is installed then the pump should be turned off and other valves used to isolate the UV.

1. Remove the UV bulb as described on page 20.
2. With the electricity supply disconnected, UV isolated and UV Bulb removed, unscrew the locking nut at one end of the UV, ensuring the End Cap O-Ring remains in place.
3. Carefully remove the quartz sleeve O-Ring and keep safe.
4. Unscrew the locking nut from the other end, ensuring the End Cap O-Ring remains in place, and remove the quartz sleeve O-Ring and keep safe.
5. Carefully remove the quartz sleeve taking care not to allow it to drop inside the UV body.
6. To drain any water that may be left in the unit, we would recommend that you unscrew the mounting bracket(s), disconnect the unit from the pipework, and tilt the unit to drain the chamber of water.
7. Clean the sleeve and polish with a soft cloth or paper towel. *If you live in a hard water area, you may get limescale on the quartz sleeve; this can be easily removed by using vinegar or a cold water descaler.*

**WARNING:** If the end caps / electrical connections get wet during this procedure, please ensure that they are thoroughly dried before re-connecting.

### TO RE-INSTALL A QUARTZ SLEEVE:

Follow the instructions on **pages 11 and 19** to re-install the quartz sleeve and UV bulb.

**IMPORTANT:** After checking all the fittings are correctly tightened you can switch your unit back on.

### TROUBLESHOOTING

During this procedure or if you notice water leaking from around the end caps you should check the following:

1. Check the O-Ring is undamaged.
2. Check there are no cracks and breaks in the quartz sleeve.
3. Check that the locking nut is compressing the O-Ring to form a water tight seal.
4. Check that the end caps are sufficiently tight.
5. All components are clean and free from dirt and debris.

***\*Please note that service items are not subject to a claim under warranty. The service items listed on pages 8 and 9 are available from your EA stockist.***

## **ELECTRICAL BALLAST BOX REPLACEMENT**

The electrical box with ballast can be easily replaced in the event of any electrical issues. This easy to install box comes with a ballast enclosed, lamp connectors, end caps and mains cable so it can be easily swapped over in the event of any electrical issues.

Spare electrical boxes are available to buy from your Evolution Aqua dealer or via our spare parts store on our website.

## **IN BUILT PROTECTION**

The evoUV Ti range of pond clarifiers have thermal overload protection which automatically shuts down and then enables a fast re-start when the problem has been cleared. This may be as a result of water in the end caps. Please see the troubleshooting section.

### **Thermal Overload Protection -**

This will automatically switch off the unit should the temperature exceed the maximum operating temperature limits.

### **Automatic start up and shut down protection -**

This protects the electrical components in the event of a power surge.

## TROUBLESHOOTING

### **My pond water is not clear, is this due to the evoUV Ti not working correctly?**

Koi, goldfish and other pond inhabitants can cause murky water by stirring up the bottom of the pond. This murky water should not be confused with suspended algae. Always check all your pond filtration is working and is being maintained correctly prior to checking the evoUV Ti. Mechanical filtration is necessary.

### **If the UV bulb is not lit, then you need to investigate the power to your unit.**

- Has your RCD tripped? If yes, check your wiring and reset.
- Examine the UV bulb for signs of failure, and replace if necessary.
- Is the UV bulb fitted correctly? Unscrew the end caps and ensure correct fitting as per the instructions as described in this manual.
- Are the end caps dry? If not, allow to dry thoroughly.  
We recommend the use of a hair-dryer for this.

### **The unit worked well when I first installed it but recently my pond has gradually gone green again – what is wrong?**

Quartz sleeve may have become dirty and requires cleaning. Also make sure you have the right model for your pond size. Ensure your pond filtration is removing fish waste and debris efficiently. Dirt in ponds will affect the efficiency of the evoUV Ti. Check that your pond water volume is pumping through the evoUV Ti every 2 to 3 hours.

Only after you have carried out these checks should you contact your Evolution Aqua dealer, who will then be able to advise you further.

### **The unit appears to be leaking from the end fittings?**

This could possibly be caused by an incorrectly fitted, damaged or overtightened O-Ring on the quartz sleeve. Please check the quartz sleeve O-Ring, reposition it or if necessary replace it with a new one. Follow the steps on page 17 to test.



SCAN  
FOR  
VIDEO

### **IMPORTANT: Do not fit the bulb socket or end cap until the issue is solved.**

If water enters the bulb socket it can cause irreparable damage to bulb socket and ballast. Damage caused by improper fitting of the quartz sleeve, o-rings and locking nuts are not covered under warranty.

### **The ballast appears to have failed.**

Replacement ballast boxes including ballasts, wires and lamp connectors can be purchased as a spare part from Evolution Aqua stockists. See the evoUV Ti spares section on our website.

## FREQUENTLY ASKED QUESTIONS

### **How often should I change the UV bulb?**

The evoUV Ti bulb has an effective lifespan of 9000 hours, but it is an accepted practice to replace a UV bulb once a year, at the start of every pond season.

### **How long after I install the unit will my pond become clear?**

There are many factors which affect how long your evoUV Ti will take to clear your pond, such as the levels of nutrients available to the algae, the water temperature and the level of sunlight. Assuming that you have installed the correct size unit, most ponds should clear within 3-14 days. However, this may take up to six weeks in some instances.

### **Does the evoUV Ti harm fish, plants or wildlife?**

Ultraviolet bulbs leave no residues, and only affect the water pumped through the unit. Unlike many chemical treatments, your evoUV Ti will not harm plants and animals living in the main pond.

### **Is the evoUV Ti suitable for salt water use?**

The evoUV Ti is manufactured from materials that will not corrode in salt water, however the stainless steel bracket will. Use alternative mounting means when using evoUV Ti on saltwater systems.

### **Can I use my evoUV Ti if I am using any treatments for my fish?**

Always check the manufacturer's instructions before using any water treatment as they will tell you whether it's recommended that the evoUV Ti can be switched off or on.

### **How long can I leave the unit running?**

evoUV Ti have been designed and manufactured to the highest standards, and should be run 24 hours a day, every day, from mid March to early October, depending on the weather conditions. If the unit is frost protected it may be left running throughout the winter. Otherwise, the unit should be removed, drained and stored safely for the winter.

### **Can I bury the unit underground?**

No. The evoUV Ti, although weatherproof, is not suitable for installing in any situation that may be subject to immersion in water.

### **Can it be used with ozone?**

Yes. The evoUV Ti is safe to use with ozone units, however, the O-Rings on the hoses are not. When using ozone units please use rigid pipe.

### **When replacing the bulb I cannot locate it into the bulb socket at the opposite end of the evoUV Ti?**

Please follow the procedure for cleaning / replacing the quartz sleeve. This will explain the correct procedure for removing both end caps and sockets and explain the method for easy installation.

## **GUARANTEE**

This product is guaranteed against defects in material and workmanship for 2 years from the date of purchase, under normal usage. The guarantee DOES NOT APPLY in case of improper use, negligence, lack of maintenance or accidental damage to the UV. If the UV fails due to a manufacturing fault within this period it will be either repaired or replaced free of charge. Liability is limited to replacement of the faulty product only; no other costs will be reimbursed. This guarantee is not transferable and does not affect your statutory rights. This guarantee does not confer any rights other than those expressly set out above. This guarantee does not cover the UV bulb or quartz sleeve.

**This unit should only be installed by a qualified electrician.**

The manufacturer or supplier shall not be responsible, or held liable for any damages caused by defective components or materials of this product; or for loss incurred by interruption of service; or any consequential/incidental damages and expenses arising from the production, sale use or misuse of this product or any other consequential loss.

Any warranty claim must be accompanied by a valid, dated proof of purchase.

Evolution Aqua and its dealers shall not be held liable for any consequential loss as a result of any failure or defect of this product.

The installation and use of your product outside of our recommendations as printed in this manual may also void the warranty.

---

## **REGISTER YOUR WARRANTY ONLINE**

The easiest way to register your warranty is to visit our website online at  
**[www.evolutionaqua.com/product-warranty](http://www.evolutionaqua.com/product-warranty)**

## NOTES

## NOTES

# VISIT OUR WEBSITE AND FOLLOW US ON SOCIAL MEDIA



For all the latest Evolution Aqua news sign up to our email newsletter to have the newest info delivered direct to your inbox. Keep up to date by following us on social media, join our Pond Owners Club on Facebook or check out our website for technical information and product advice at [www.evolutionaqua.com](http://www.evolutionaqua.com).



## INSTRUCTION MANUALS

Download instruction manuals for all Evolution Aqua products



## PARTS STORE

Find spare parts and accessories for Evolution Aqua products



## FAQS

Read frequently asked questions about Evolution Aqua products



## EMAIL NEWSLETTERS

Sign up to receive our email newsletters at [evolutionaqua.com/newsletter](http://evolutionaqua.com/newsletter)



## STOCKISTS

Locate your nearest Evolution Aqua product stockist



## EA POND OWNERS CLUB

Search Evolution Aqua Pond Owners Club on Facebook to join the community



## FACEBOOK

Keep updated with our latest news at [facebook.com/evolutionaqua](http://facebook.com/evolutionaqua)



## INSTAGRAM

Follow us on Instagram for updates at [instagram.com/evolution\\_aqua](http://instagram.com/evolution_aqua)



## TIKTOK

Follow us on TikTok at [tiktok.com/@evolution\\_aqua](http://tiktok.com/@evolution_aqua)



## YOUTUBE

Watch our YouTube channel at [youtube.com/evolutionaqualtd](http://youtube.com/evolutionaqualtd)

## Evolution Aqua Ltd

Kellet Close  
Wigan  
Lancashire  
United Kingdom  
WN5 0LP

[www.evolutionaqua.com](http://www.evolutionaqua.com)

