

EPC050925MAN

UK
English

EPA Est. No. 100154-GBR-1

EVOLUTION
AQUA

INNOVATION IN WATER

eazypodTM complete



INSTALLATION AND OPERATING MANUAL

WARNING:

Ensure that the UV is **switched off** at the mains before you attempt to conduct any type of maintenance on the EazyPod Complete.

WARNING: PLEASE READ THE FOLLOWING SAFETY INFORMATION FIRST.

IMPORTANT SAFETY INFORMATION

- Please Read Carefully
- Never look directly at an illuminated UV bulb.
- Do not run this unit dry.
- Please ensure that the EazyPod Complete is full of water before switching it on.
- Always isolate the unit from mains electricity and turn off any water supply before carrying out any maintenance.
- Always disconnect all pond appliances from the mains supply before putting your hands into the water.
- Use in the area of the garden pond only if the installation complies with the relevant wiring regulations.
- Power must be supplied through a Residual Current Device (RCD) with a residual operating current not exceeding 30mA.
- This unit must be earthed. Never use a fuse larger than 3 amps on the power lead.
- The unit must not be submerged in water.
- If the quartz sleeve is cracked, replace it immediately.
- The unit must be either fully frost protected or taken inside during Winter months.
- Young children should always be supervised near water.
- Max. ambient temperature where ballast is installed must not exceed 35°C.
- DO NOT put the UVC ballast in direct sunlight.



PRODUCT INFORMATION

- **Rating:**
220-240V, 50Hz.
18 Watt UV
- All units are IP54. All units are CE approved.
- UV Bulb Specification: 18 Watt PL-L UV-C Bulb



Disposal Of Your Old Product

Your product is designed and manufactured with high quality material and components, which can be recycled and reused. When this crossed-out wheeled bin symbol is attached to a product, it means the product is covered by the European Directive 2002/96/EC. Please contact your local authority about correct disposal for electrical and electronic equipment. Our WEE Registration Number is WEE/FE1471RR.

Please act according to your local rules and do not dispose of your old products with your normal household waste. The correct disposal of your old product will help prevent potential negative consequences for the environment and human health.

EPA Est. No. 100154-GBR-1



INTRODUCING THE EAZYPOD COMPLETE

Congratulations on purchasing an Evolution Aqua EazyPod Complete.

The EazyPod Complete is an adaption of one of Evolution Aqua's most successful filters, the EazyPod. The EazyPod Complete is a mechanical and biological filter system with an integrated 18 Watt UV clarifier. The EazyPod Complete is ideal for all ponds of up to 10,000 litres. The addition of the built in UV Clarifier now enables the EazyPod Complete to clear green water, caused by single celled algae, as well as filtering organic and biological waste produced by your pond fish.

CONTENTS

EazyPod Complete Overview	PAGE 4
Components	PAGE 5
Specification and Flow Rates	PAGE 6
Dimensions	PAGE 7
Installation	PAGE 8
Air Pump Installation	PAGE 11
K1 Micro Installation	PAGE 12
Connection to the electricity supply	PAGE 12
Commissioning and Switching on the EazyPod Complete	PAGE 13
Maintenance Advice	PAGE 14
Cleaning the EazyPod Complete	PAGE 15
Cleaning the UV Quartz Glass	PAGE 16
Replacing the UV Bulb	PAGE 17
Our Guarantee	PAGE 18

OVERVIEW

The concept of the **EazyPod Complete** is simple and yet innovative. Water enters via the inlet **(A)** and passes over an **18 watt UV** Clarifying bulb **(N)**, helping to kill any single celled algae in the water. The water then enters the outer chamber **(B)**, which runs around the entire circumference of the EazyPod. Between the outer chamber **(B)** and the inner chamber **(C)**, is a stainless steel perforated screen **(I)**. These perforations are situated in the lower half of the screen and around its entire face. This means that when the water passes from the outer to inner chamber **(B to C)**, a downward flow is created. This causes many of the larger solids to settle in the base of the outer chamber **(B)**, due to the force of gravity.

The size of the perforations will not allow large mechanical waste to enter the inner chamber **(C)**, thus acting as a first stage mechanical filter. The inner chamber holds **18 litres** of static K1 Micro. As the water enters the inner chamber, the fine smaller solids become entrapped in the K1. After passing through the K1 Micro, the clean water then rises and overflows into the inner return pipe **(F)**. From here it returns to the pond via the return outlet **(J)**.

The EazyPod Complete filtration system gives water quality and clarity that surpasses all expectations. The nature and volume of the K1 Micro means, that when static, apart from being a very efficient mechanical filter, there is more than enough surface area for beneficial bacteria to colonise. Therefore on a smaller pond, the EazyPod Complete is an excellent complete filter.

PLEASE NOTE that in normal running, the K1 Micro has to be static – it is only moved during cleaning and maintenance. If the K1 Micro is moved in normal operation, whether by air or by hand, all of the debris it has collected will be returned to the pond! The K1 Micro is cleaned and moved by connecting an air pump to the air line **(D)** in the EazyPod Complete, which in turn goes to an air ring **(H)** in the base of the inner chamber **(C)**. The air ring has small holes in it which causes the K1 Micro to move and therefore clean itself.

During the cleaning cycle, the finer particles escape into chamber **(B)** from the K1 Micro. This waste water can then be dumped via a 1.5 inch / 50mm slide valve **(K)**.

Your EazyPod Complete will help to keep your pond clear of green water. As with any filter that works in combination with a UV, the effectiveness of the UV light will depend on stocking levels, sunlight / shade, daily sunshine amounts etc.

Please check the table on page 6 to make sure you run your EazyPod Complete within our specified limits to achieve the best results.

COMPONENTS

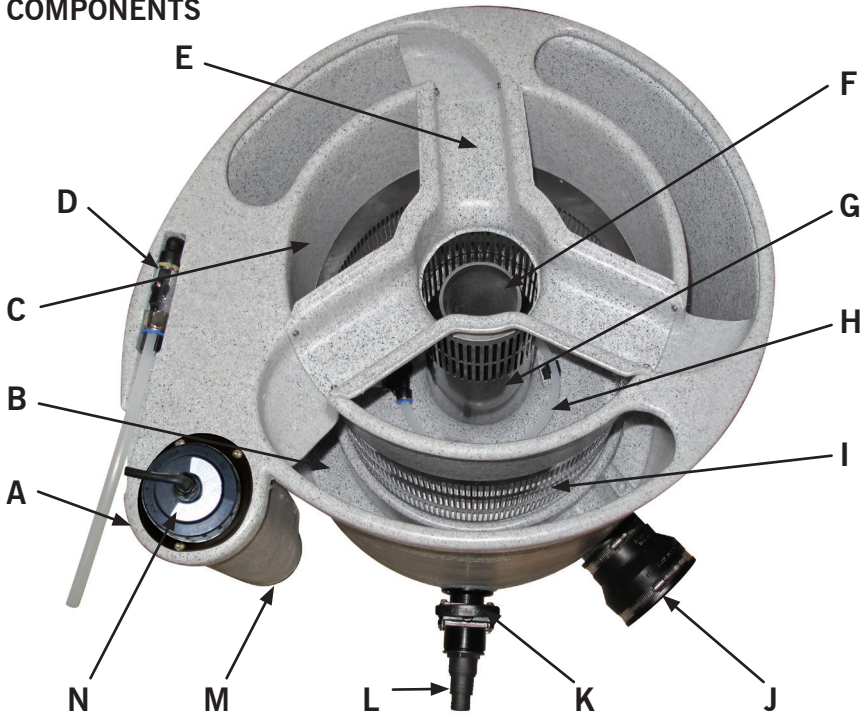

Description	EazyPod Complete
Inlet	A
Chamber B - Outer Chamber	B
Chamber C - Inner Chamber	C
Air and Valve Assembly (for cleaning)	D
Overflow Assembly	E
Return Pipe	F
Stainless Steel Perforated Pipe	G
Air Ring	H
Stainless Steel Perforated Screen	I
Outlet: 4"-3" (90-115mm) EazyConnector	J
Waste Purge 1½" (50mm) Slide Valve	K
Stepped Hosetail	L
Inlet: 1½" (50mm) Hosetail	M
UV Clarifier Bulb Unit (18 W PL-L Bulb)	N

SPECIFICATION AND FLOW RATES

The EazyPod Complete is truly multi-functional. It can be run in several different ways for different applications.

The EazyPod Complete can be used:

- as a stand alone filter on a small pond
- as a complete filter on a quarantine system
- as a pre-filter at the front of any new or existing system
- as a polisher at the end of any system
- off a mid water feed to aid mechanical filtration
- on a skimmer line as a mechanical filter

Remember that if you use the EazyPod Complete solely as a mechanical filter, you will also get an enhanced biological benefit in your system.

EazyPod Complete Specifications and Flow Rates

Follow this manual carefully and your filter will provide a perfect environment for your fish. One of the factors that can have a significant influence on our ponds is the **turn over** rate. This is the time that it takes for the total water volume of the pond to pass through the filter system once. On EazyPod Complete ponds, where it is used as the only filtration system, a total pond volume turn over of every 1 to 2 hours is required.

Therefore if you have a 10,000 litre pond, a minimum rate of 5,000 litres per hour is needed giving a 2 hour turnover, although you could also run at 10,000 litres per hour giving a turnover rate of once per hour.

Max flow rate:	10,000 litres/hr	2,200 UK gallons/hr	2,640 US gallons/hr
Max pond size for all fish	10,000 litres	2,200 UK gallons	2,666 US gallons
Max pond size with the addition of supplementary UV	20,000 litres	4,400 UK gallons	5,333 US gallons
K1 Micro	18 litres		
Max feed rate	100 - 120g per day		
AirPump	EA AirPump 70		
UV Bulb Specification	18 Watt PL-L UV-C		
UV Bulb Life	Recommended bulb change every 8000 hours		

DIMENSIONS

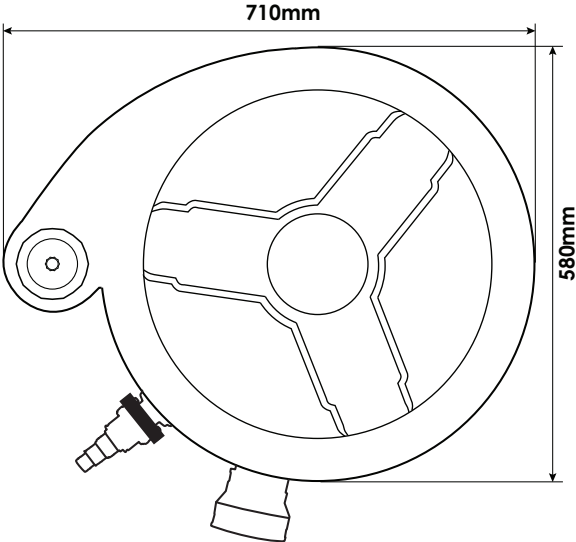
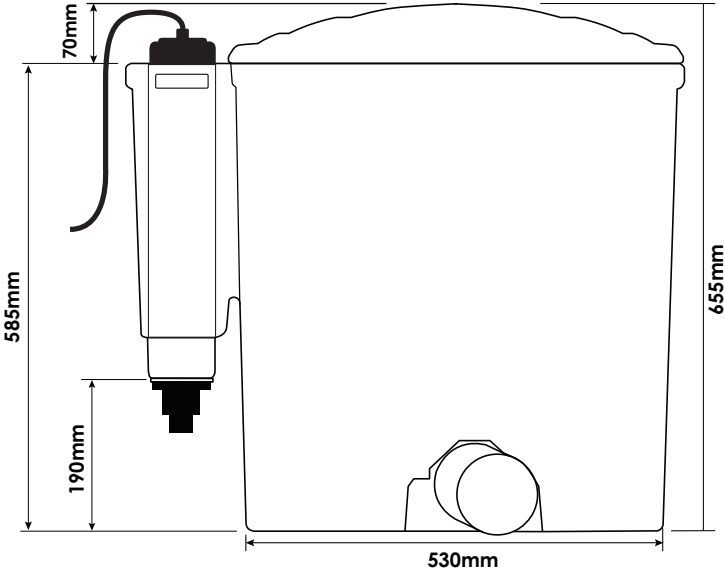

INSTALLATION

PLEASE NOTE: EazyPod Complete is designed to be used on a Pump Fed set-up only. We do not recommend installing the EazyPod Complete on a Gravity Fed set-up.

The diagram below shows the EazyPod Complete on a typical Pump Fed set-up. A Pump Fed set-up is when water is pumped from the pond to the filter.

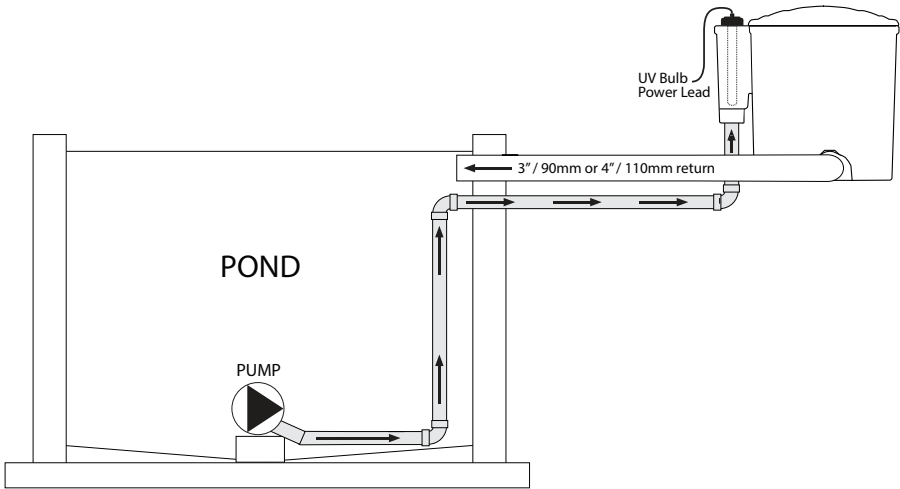

PLEASE NOTE: The pump must not be placed on the base of the pond, as failure in the pipe work or connectors could lead to complete drainage of the pond. The pump should be raised at least 12" off the ground or high enough to leave sufficient water for the fish to survive, in the unlikely event that this occurs.

INSTALLATION

PREPARATION

A solid, level base is required. It should be a minimum of 600mm x 600mm, to allow easy access to your valves and for maintenance purposes.

Important: The EazyPod Complete filter needs to be supported evenly on a level base (a paving flag is ideal). Failure to do so could cause damage when it is full of water.

INSTALLATION EQUIPMENT

1. **Pond Pump.** Please ensure that the pump's maximum actual flow rate is no more than the specified limits (see page 6).
2. **Air Pump** for cleaning the K1 Micro. An EA Airpump 70 is recommended.
3. A length of garden hose or braided pipe (10 mm inner diameter) to connect your air pump to the air ring in the EazyPod Complete.
4. **Tip:** When connecting to your air pump, cut an inch from the airline supplied on the EazyPod Complete. Insert this into the hose pipe that connects to the air pump. This will help maintain the hosepipe's rigidity when inserting it into the rubber connector and clip supplied with your air pump.

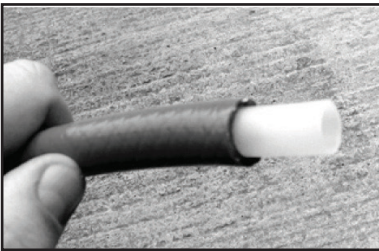

5. **Pipe work** from the unit's waste valves to the intended discharge point. This can be rigid pipe work or a simple flexible hose.

INSTALLATION

The EazyPod Complete comes to you ready to be installed on a **PUMP FED** set-up - no changes to any of the fittings are required.

The EazyPod Complete should be situated at a height above the pond water level, to allow adequate gravity return to the pond (subject to the maximum performance of your chosen pump).

The gravity return pipe work from the exit point of the EazyPod Complete to the pond needs to be a minimum of 3 inches (90mm), 4" (110m) for flow rates over 7,500 litres per hour and should have no restrictions. Great care should be taken to ensure that no air locks are created within the gravity return pipe work. The return pipe should have an "appropriate fall" from the EazyPod Complete to the pond.

The pipe work from the pond pump to the inlet of the EazyPod Complete will need to be connected to the 1.5 inch (50mm) hosetail (**M**). The 4 inch / 90-115 mm (minimum) gravity return pipe work will need to be connected to the rubber adaptor (**J**) on the outlet point of the EazyPod Complete.

This fitting when first connected to this pipe could appear too big (especially 90mm) or too large 4" (115mm) – it will however reduce/stretch with the clip provided and make a tight seal – this is done with a screwdriver. The return pipe is then extended and returned to the pond or waterfall as required.

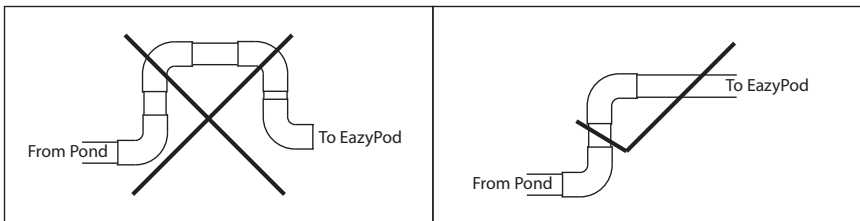

AIR PUMP INSTALLATION

Now that you have your EazyPod Complete installed, you will need to connect your air pump to the EazyPod Complete for the cleaning cycle. This will agitate the K1 Micro so that the waste which has collected in the media can be removed from the system. We recommend an EA AirPump 70.

The air pump is connected to the air ring inlet using a garden hose or braided pipe (10 mm inner diameter). The air ring inlet is positioned on the outside of the EazyPod Complete. It is recommended that the air pump is positioned higher than the water level in the EazyPod Complete to prevent water flowing back into the air pump when it is switched off. However, the air valve should be in the off position, and the air pump switched off or in use elsewhere when not in the cleaning mode.



Air Valve On



Air Valve Off



K1 MICRO INSTALLATION

Now that you have your EazyPod Complete installed, you will need to add the 18 litres of K1 Micro that was supplied with the EazyPod Complete. Simply empty the entire bag into the inner chamber **(C)**.

CONNECTION TO THE ELECTRICITY SUPPLY

Electrical installations must be done by a qualified electrician.

The power supply must meet the specifications on the product. The cores in the supply cable are coloured in accordance with the following code:

Brown = Live. Blue = Neutral. Earth = Green/Yellow.

Do not use the cable to lift the EazyPod Complete as this may cause damage.

WARNING - A Residual Current Device (RCD), also known as the Residual Current Circuit Breaker (RCCB), with a tripping current not exceeding 30mA must be installed in the supply circuit. A means of disconnection from the supply having a contact separation of at least 3mm in all poles must be incorporated in the wiring.

Caution: Use in the area of the garden pond only if the installation complies with the relevant wiring regulations. Please consult a qualified electrician.

Caution: Always disconnect all pond appliances from the mains supply before putting your hands into the water.

All electrical installations and wiring must be adequately protected to prevent any damage.

Enough electrical cable is supplied with the UV to connect to the mains electric. This unit must be connected to permanent wiring. A switch with 3mm contact separation must be provided in the fixed wiring to provide disconnection from the electricity supply.



COMMISSIONING & SWITCHING ON THE EAZYPOD COMPLETE

Before you run your EazyPod Complete, you should first check that you have installed the filter and pipework correctly.

Having taken a last look at your pipework to ensure that everything looks right, switch on the circulating pond pump, and check for any leaks.

Only after you have satisfied yourself that the EazyPod Complete is installed correctly should you switch on the electricity supply to the unit.

Your EazyPod Complete is now up and running.



MAINTENANCE

Cleaning and maintaining the EazyPod Complete will depend on flow rate, feed, stocking, blanket weed etc.

An EazyPod Complete on a summer pond with heavy blanket weed will need more frequent maintenance than a pond in December with no food fed. Be aware that any movement of the K1 Micro in the EazyPod Complete whilst the pond pump is in operation will dislodge the waste collected and will be sent back to the pond and clarity will suffer. If this does happen, the EazyPod Complete will eventually remove this waste again in time. Please read the cleaning instructions for the EazyPod Complete before attempting the cleaning procedure.

PLEASE NOTE: A pump fed system will need cleaning when the water level in chamber **B / C** has risen and is close to the overflow assembly.

MAINTENANCE ADVICE

To achieve optimum water quality and clarity we recommend that the EazyPod Complete be air backwashed and purged on a regular basis. The frequency of cleaning will depend on the loading of the pond. However, the filter must be cleaned regularly.

In the event of a blockage, the chamber will overflow on a pump fed system. The overflow assembly (**E**) has a built in overflow. Should a blockage of the K1 Micro occur, water will bypass the stainless steel screen and return to the pond.

CLEANING THE EAZYPOD COMPLETE

1. Switch off the water pump.
2. Wait until water has stopped flowing back to the pond.
3. Turn on your air pump and open the air valve on the EazyPod Complete. In a few seconds the K1 Micro will start to 'agitate' and circulate, thereby self cleaning.
4. After the K1 Micro has been aerated for a minimum of two minutes, open valve **(K)** and completely drain the EazyPod Complete.
5. Once it is drained, close valve **(K)**.
6. Turn on your circulation pump to refill the EazyPod Complete.
7. If you want to clean the EazyPod Complete for a second time, repeat steps 1 to 6.

PLEASE NOTE that normally 2 cleaning cycles will be needed to completely clean the K1 Micro. On a dirty pond, maybe even 3 will be needed.

Optional Cleaning - Pump-fed Procedure - Using the cleaning pipe

The new inlet configuration of the EazyPod Complete means that it is not essential to use the cleaning pipe to maintain the water level during cleaning.

However, should you find that excessive debris is splashed down the return pipe during cleaning you can use the cleaning pipe provided to isolate the unit from your pond.

Insert the cleaning pipe then follow the steps 1 to 5 above.

Remember to remove the cleaning pipe before switching your pump back on.

CLEANING THE UV QUARTZ GLASS

ALWAYS ISOLATE THE UNIT FROM ANY ELECTRICITY AND WATER SUPPLIES BEFORE CARRYING OUT MAINTENANCE ON THE UNIT.

If you notice an increase in algae formation and/or see that limescale is forming, you will need to check that the UV bulb is working properly. To ensure peak efficiency, the UV bulb must be replaced every 8000 hours of operation.

How to Clean the UV Quartz glass:

1. Unplug the UV light's power plug.
2. Switch off the water pump.
3. Unscrew the black cable grommet and UV retaining collar and carefully pull out the device head along with the UV bulb (**please do not touch the UV bulb**) (FIG. 16.1 - 16.3)
4. To remove the quartz sleeve carefully ease out from inside the unit. This may be tight. (FIG. 16.4)
5. Now you can clean the quartz sleeve with a damp cloth.
6. Check the quartz sleeve for damage before putting it back.
7. Put the Quartz glass back in the unit and be sure that the orange O-ring is in place and is clean.
8. Check that the black O-ring is in the groove of the quartz sleeve. (FIG. 16.5)
9. Put the device head back in the Quartz sleeve and screw it tight. (FIG. 16.7)
10. Tighten the cable grommet to secure the cable. (FIG. 16.8)
11. Switch on the water pump and check for any leaks.
12. Now you can switch on the UV.



FIGURE 16.1



FIGURE 16.2



FIGURE 16.3

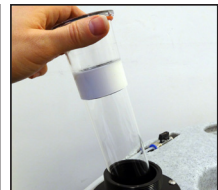

FIGURE 16.4



FIGURE 16.5



FIGURE 16.6



FIGURE 16.7



FIGURE 16.8

As already mentioned, it is essential that the unit is protected from frost during the winter months, or disconnected from water and electricity supplies and stored indoors. During the spring and summer season, the quartz sleeve, which separates the UV bulb from the water passing through the unit, will need to be cleaned two or three times. This is essential, as dirt or limescale building up on the quartz sleeve will inhibit the penetration of the ultraviolet light into the water and affect the efficient working of the unit.

CLEANING THE UV QUARTZ GLASS

ALWAYS ISOLATE THE UNIT FROM ANY ELECTRICITY AND WATER SUPPLIES BEFORE CARRYING OUT MAINTENANCE ON THE UNIT.

If you notice an increase in algae formation and/or see that limescale is forming, you will need to check that the UV bulb is working properly. To ensure peak efficiency, the UV bulb must be replaced every 8000 hours of operation.

How to Replace the UV Bulb: (You will to purchase a replacement 18 Watt PL-L UV Bulb)

1. Unplug the UV light's power plug.
2. Switch off the water pump.
3. Unscrew the black cable grommet and UV retaining collar and carefully pull out the device head along with the UV bulb (**please do not touch the UV bulb**) (FIG. 17.1 - 17.3)
4. When removing the UV bulb it is better to use a dry cloth to hold the UV bulb.
5. Now you can clean the quartz sleeve with a damp cloth.
6. When replacing the tube, please remove the bulb transit clip (if present). (FIG. 17.4)
7. Now you can remove the 18 Watt PL-L UV bulb. (FIG. 17.5)
8. Put a new 18 W PL-L UV bulb in the four pin socket. You do not need to replace the transit clip as it is no longer needed. (FIG. 17.6)
9. Check that the black O-ring is in the groove of the quartz sleeve.
10. Put the device head back in the Quartz sleeve and screw it tight. (FIG. 17.7)
11. Tighten the cable grommet to secure the cable. (FIG. 17.8)
12. Switch on the water pump and check for any leaks.
13. Now you can switch on the UV.



FIGURE 17.1



FIGURE 17.2

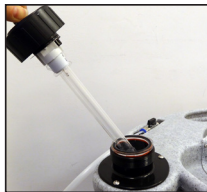

FIGURE 17.3



FIGURE 17.4



FIGURE 17.5

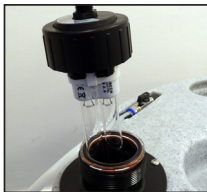

FIGURE 17.6



FIGURE 17.7



FIGURE 17.8

As already mentioned, it is essential that the unit is protected from frost during the winter months, or disconnected from water and electricity supplies and stored indoors. During the spring and summer season, the quartz sleeve, which separates the UV bulb from the water passing through the unit, will need to be cleaned two or three times. This is essential, as dirt or limescale building up on the quartz sleeve will inhibit the penetration of the ultraviolet light into the water and affect the efficient working of the unit.

OUR GUARANTEE

This product comes with a 2 year warranty, which is valid from date of purchase. Proof of purchase will be required. Any unauthorised repairs, modifications or alterations to this unit will invalidate the warranty.

Evolution Aqua accepts no responsibility or liability due to accident, improper installation or misuse. Liability is limited to replacement of the defective parts. This guarantee does not cover the UV bulb or quartz sleeve in the EazyPod Complete. This guarantee is not transferable. It does not affect your statutory rights.

Evolution Aqua and its dealers shall not be held liable for any loss of fish, plants or any other livestock as a result of any failure or defect of this product.

If there is a warranty issue please contact Evolution Aqua's Technical Service department. Claims for transport damage shall only be recognized if the damage is reported within 24 hours after delivery and confirmed by the carrier.

Evolution Aqua reserve the right to change this product specification without prior notice.

All products designed to ISO 9001 and manufactured to ISO 9000
Patent Information: GB2.293333B; WO/00 61258; PCT/GB01/05533;
PCT/GB01/05549; 0750591;
0575314; 5,543,039; 5,458,779; 6126829; 689246; 2119893; 3183406

Evolution Aqua are the award winning pond filtration manufacturer who put innovation, research and development at the top of their agenda. With a proven track record for delivering the latest technology to the aquatics and fish farming markets - we are the first choice for everyone from the general hobbyist to the serious fishkeeper. Find out more about the EazyPod Complete and all of our other innovative products at www.evolutionaqua.com. The difference is clear.



Evolution Aqua Ltd

Evolution House
Kellet Close
Wigan
Lancashire
United Kingdom
WN5 0LP

t: +44 (0) 1942 216554
f: +44 (0) 1942 418489
e: info@evolutionaqua.com
w: www.evolutionaqua.com

eazypod^ocomplete

QUALITY ASSURANCE CHECK

EVOLUTION
AQUA
INNOVATION IN WATER

PARTS	QUANTITY	QTY PICKED
EAZYPOD COMPLETE	1	
18 LITRES OF K1 MICRO	1	
18 WATT UV (INSTALLED)	1	
4" TO 3" EAZYCONNECTOR	1	
1½" HOSETAIL (Pre-cut one for inlet)	2	
AIRPUMP 70	1	
10m ROLL OF SILICONE AIRLINE	1	
4 PORT CHROME MANIFOLD	1	
AIRSTONE	2	
MANUAL	1	
RUBBER ELBOW	2	
2cm SILICONE TUBING	2	
10cm AIRLINE (12mm)	2	
12mm TEE	1	
80cm AIRLINE (12mm)	1	
CLEANING PIPE	1	

CHECKLIST	CHECKED BY
Is 18 watt UV working?	
Is AirPump 70 in the box?	
Is there a sticker on the box to say it contains the Eazypod Complete?	

Packed By: _____

Date: _____

IF ANY PARTS ARE MISSING, PLEASE CONTACT EVOLUTION AQUA ON 01942 216554 IMMEDIATELY.